

DATA SHEET

DIESEL GENERATOR 200KW

MODEL#FDK-D200E/H2

60HZ/1800RPM

DOOSAN MODEL: P086TI



General Features:

- ♦ All qualified generator sets are subjected to a comprehensive performance test which includes 50% load, 70% load, 100% load, 110% load and to check, verify that all control systems, alarm and shut-down protection.
- ♦ Equipped with battery charger and 24V high performance maintenance-free lead-acid starting batteries and connecting cables.
- ♦ Stainless galvanized zinc plates with strong corrosion-proof.
- ♦ Vibration isolators between the engine/alternator and base frame.
- ♦ Equipped with industrial silencer and flexible exhaust hose.
- ♦ Designed to comply with ISO8528/GB2820.
- ♦ Powered by Doosan engine and coupled with Stamford alternator.
- ♦ Water jacket preheater, oil heater and double air cleaner, etc. are available.

FDK Diesel Generator Set Data

Genset Model	FDK-D200E/H2
Prime Power	180KW/225KVA
Standby Power	200KW/250KVA
Output Frequency / Rated speed	60Hz/1800rpm
Rated Voltage	230V/400V

Engine Make	Doosan (CHINA XCMG)
Engine Model	P086TI
Alternator model	Stamford UCI274H
Control System	DSE7320
Phase	Three

(1) **Prime power:** The rating is available for an unlimited of annual operating hours in variable load applications, in accordance with ISO8528-1.A 10% overload is available for a period of 1 hour within 12-hour period of operation, in accordance with ISO 3046-1.

(2) **Standby power:** The rating is applicable for supplying emergency power in variable load applications for up to 200 hours per year in accordance with ISO8528-1. Overload is not allowed.

(3) **Rated voltage:** available with customer requirement.

Engine Specifications (DETAILED in APPENDIX)

Engine Model	P086TI
Engine Manufacturer	Doosan (CHINA)
Cylinder quantity	6
Cylinder Arrangement	In-line
Cycle	Four stroke
Aspiration	Turbo charged

Bore x Stroke (mm x mm)	111x139
Displacement	8.071L
Compression Ratio	16.4:1
Prime power / Speed (KW/RPM)	205/1800
Standby power/ Speed (KW/RPM)	223/1800
Speed governor	Electric type



Piston Speed	8.34m/s
Friction Energy Output	24kw
Total Lubrication System Capacity (L)	15.5
Coolant Capacity (L)	14

Fuel Consumption at 100% load (liters/hr)	50.6 at 1800rpm
Starter motor	24V
Alternator	24V
Low idle	800-1980RPM

Alternator Specifications

Alternator model	UCI274H
Alternator manufacturer	STAMFORD
Exciter type	Single bearing, Brushless, Self-excited
Rated output prime power	245 KVA
Rated speed	1800 rpm
Rated frequency	60Hz

Number of phase	3
Rated voltage	440V (Available with custom requirements)
Power factor	0.8
Voltage regulation NL-FL	±1%
Insulation grade	H
Protection grade	IP23

Alternator option: Leroy Somer, MECC, Marathon, Engga, Faraday

Control System DSE7320 (DETAILED in INSTRUCTION)

DSE7320 is an advanced control module based on micro-processor, containing all necessary functions for protection of the genset and the breaker control. It can monitor the mains supply, breaker control and automatically start the engine when the mains are abnormal. Accurately measure various operational parameters and display all values and alarms information on the LCD. In addition, the control module can automatically shut down the engine and indicate the engine failure.

FEATURES

- ♦ Microprocessor control, with high stability and credibility.
- ♦ Monitoring and measuring operational parameters of the mains supply and genset.
- ♦ Indicating operation status, fault conditions, all parameters and alarms.
- ♦ Multiple protections; multiple parameters display, like pressure, temp. etc.
- ♦ Manual, automatic and remote work mode selectable.
- ♦ Real time clock for time and date display, overall runtime display, 250 log entries.
- ♦ Overall power output display.
- ♦ Integral speed/frequency detecting, telling status of start, rated operation, overspeed etc.
- ♦ Communication with PC via RS485 OR RS232 interface, using MODBUS protocol.

Soundproof Enclosure Specification

FDK silent generator is designed by professional acoustic engineers based on years of experience. Now we can make the noise of the generator less than 80-85dB(A) at 1m, or 70-75dB(A) at 7m, 60-65dB(A) at 15m.

FEATURES

- ♦ Multi-way air intake and exhaust guarantee the power performance of the generator.
- ♦ Large-scale impedance combined type silencer effectively reduce noise of the generator.
- ♦ Internal high performance rubber damper and flexible materials reduce vibration.
- ♦ Base mounted fuel tank supports the generator running for 8 hours.



ISO9001:2008

FDK reserves the right to change the specifications and designs without notice.

Optional

Generator set	Alternator	Low environment Temp	ATS
<input type="checkbox"/> Open generator set <input type="checkbox"/> Silent generator set <input type="checkbox"/> Trailer generator set <input type="checkbox"/> ABB MCCB circuit breaker	<input type="checkbox"/> Stamford <input type="checkbox"/> Marathon <input type="checkbox"/> Mecc Alte <input type="checkbox"/> Leroy Somer <input type="checkbox"/> Farady <input type="checkbox"/> Engga	<input type="checkbox"/> Water heater <input type="checkbox"/> Oil heater <input type="checkbox"/> Battery heater	<input type="checkbox"/> CHINT <input type="checkbox"/> SCHNEIDER <input type="checkbox"/> ABB
Fuel system	Control system	Voltage	Synchronized system
<input type="checkbox"/> 12hrs base tank <input type="checkbox"/> 24hrs base tank <input type="checkbox"/> Dual wall base fuel tank <input type="checkbox"/> Outside fuel tank	<input type="checkbox"/> AMF function <input type="checkbox"/> ATS control cabinet <input type="checkbox"/> DSE7320 <input type="checkbox"/> DSE7510 <input type="checkbox"/> GU620A	<input type="checkbox"/> 415/240V <input type="checkbox"/> 400/230V <input type="checkbox"/> 380/220V <input type="checkbox"/> 220/127V <input type="checkbox"/> 200/115V	<input type="checkbox"/> CHINT Cabinet <input type="checkbox"/> SCHNEIDER Cabinet <input type="checkbox"/> DSE8610 Module <input type="checkbox"/> COMAQ Module <input type="checkbox"/> DEIF Module

Dimension & Weight

Open

Overall Size: LxWxH (mm)	2350x930x1450
Weight (kg)	1750

Soundproof Version

Overall Size: LxWxH (mm)	3650x1350x1900
Weight (kg)	2300

Sales Promises

- ◆ FDK provides a full line of brand new and high quality products. Each and every unit is strictly factory tested before shipment.
- ◆ Quality warranty is according to our standard conditions: 12 months from BL date or 1000 running hours, whichever comes first.
- ◆ Service and parts are available from FDK or distributors in your location.
- ◆ FDK guarantee use **BRAND NEW & GENUINE MACHINE.**



DOOSAN INFRACORE GENERATOR ENGINE

P086TI



Ratings (kWm/PS)	Gross Engine Output		Net Engine Output	
	Standby	Prime	Standby	Prime
1500rpm(50Hz)	199/270	177/240	194/263	172/233
1800rpm(60Hz)	223/303	205/279	215/292	197/268

Ratings Definitions

The power ratings of Emergency Standby and Prime are in accordance with ISO 8528.

Fuel Stop power in accordance with ISO 3046.

STANDBY POWER RATING is applicable for supplying emergency power for the duration of the utility power outage.

No overload capability is available for this rating. A standby rated engine should be sized for a maximum of an 80% average load factor and 200 hours of operation per year. This includes less than 25 hours per year at the Standby Power rating.

PRIME POWER RATING is available for an unlimited number of hours per year in variable load application. Variable load should not exceed a 70% average of the Prime Power rating during any operating period of 250 hours. The Total operating time at 100% Prime Power shall not exceed 500 hours per year. A 10% overload capability is available for a period of 1 hour withing a 12 hour period of operation. Total operating time at the 10% overload power shall not exceed 25 hours per year

◎ GENERAL ENGINE DATA

○ Engine Model	P086TI
○ Engine Type	4-Cycle, In-line, 6-Cylinder Diesel, water cooled, Turbo charged & intercooled
○ Bore x stroke	111 x 139 mm
○ Displacement	8.071 liters
○ Compression ratio	16.4 : 1
○ Rotation	Counter clockwise viewed from Flywheel
○ Firing order	1-5-3-6-2-4
○ Injection timing	12°±1° BTDC
○ Dry weight	790kg(with Fan)
○ Dimension (LxWxH)	1,242 x 923 x 1,095 mm
○ Fly wheel housing	SAE NO.1M
○ Fly wheel	Clutch NO.14M
○ Number of teeth on flywheel	146

◎ ENGINE MOUNTING

Maximum Bending Moment at Rear Face to Block	1325 N · M
--	------------

◎ EXHAUST SYSTEM

Maximum Back Pressure	5.9 kPa
-----------------------	---------

◎ AIR INDUCTION SYSTEM

Maximum Intake Air Restriction	
. With Clean Filter Element	2.16 kPa
. With Dirty Filter Element	6.23 kPa
○ Max. static pressure after Radiator	0.125 kPa

◎ COOLING SYSTEM

Water circulation by centrifugal pump on engine.

○ Cooling method	Fresh water forced circulation
○ Coolant capacity	Engine Only : Approx. 14 lit., With Radiator : Approx 44 lit.(standard)
○ Coolant flow rate	166 liters / min
○ Pressure Cap	Max. 49 kPa
○ Water Temperature	
- Maximum for standby and Prime	103°C
- Before start of full load	40.0°C
○ Water pump	Centrifugal type driven by belt
○ Thermostat Type and Range	Wax – pellet type, Opening temp. 71°C , Full open temp. 85°C
○ Cooling fan	Blower type, Plastic , 660 mm diameter, 7 blade
○ Max. external coolant system restriction	Not Available

◎ LUBRICATION SYSTEM

Force-feed lubrication by gear pump, lubricating oil cooling in cooling water circuit of engine.

○ Lub. Method	Fully forced pressure feed type
○ Oil pump	Gear type driven by crank-shaft gear
○ Oil filter	Full flow, cartridge type
○ Oil pan capacity	Max. 15.5 liters , Min. 12 liters
○ Lub oil pressure	Idle Speed : Min 100 kPa Governed Speed : Min 250 kPa
○ Maximum oil temperature	120°C
○ Angularity limit	Front down 15 deg , Front up 15 deg , Side to side 15 deg
○ Lubrication oil	Refer to Operation Manual

◎ FUEL SYSTEM

Bosch type in-line pump with integrated, electromagnetic actuator.

○ Injection pump	Doowon in-line "P" type (Licensed by ZEXEL)
○ Governor	Electric type (all speed control)
○ Speed drop	G3 Class (ISO 8528)
○ Feed pump	Mechanical type in injpump.
○ Injection nozzle	Multi hole type
○ Opening pressure	22.0 MPa
○ Fuel filter	Full flow, cartridge type with water drain valve.
○ Maximum fuel inlet restriction	10 kPa
○ Maximum fuel return restriction	60 kPa
○ Fuel feed pump Capacity	230 liters / hr
○ Used fuel	Diesel fuel oil

◎ ELECTRICAL SYSTEM

○ Battery Charging Alternator	28.5V x 45A alternator
○ Voltage regulator	Built-in type IC regulator
○ Starting motor	24V x 6.0 kW
○ Battery Voltage	24V
○ Battery Capacity	100 Ah (recommended)
○ Starting aid (Option)	Block heater

◎ VALVE SYSTEM

○ Type	Overhead valve type	
○ Number of valve	Intake 1, exhaust 1 per cylinder	
○ Valve lashes at cold	Intake 0.3mm , Exhaust 0.3mm	
○ Valve timing	Opening	Close
- Intake valve	16 deg. BTDC	36 deg. ABDC
- Exhaust valve	46 deg. BBDC	14 deg. ATDC

◎ PERFORMANCE DATA

		Prime Power		Standby Power	
○ Governed Engine speed	rpm	1500	1800	1500	1800
○ Engine Idle Speed	rpm	800	800	800	800
○ Over speed limit	rpm	1650	1980	1650	1980
○ Gross Engine Power Output	kW	177	205	199	223
	ps	240	279	270	303
○ Break Mean effective pressure	Mpa	1.75	1.70	1.97	1.84
○ Mean Piston Speed	m/s	6.95	8.34	6.95	8.34
○ Friction Horsepower	kW	18	24	18	24
	ps	24.47	32.63	24.47	32.63
○ Specific fuel consumption					
25% load	liters/hr	11.3	13.8	12.7	15.2
50% load	liters/hr	21.1	25.1	23.7	27.7
75% load	liters/hr	31.7	37.7	35.5	41.6
100% load	liters/hr	43.1	50.6	48.4	56.8
○ Maximum Lube oil consumptic	g/h	168	195.3	189	212.1
○ Fan Power	kW	5	8	5	8
○ Exhaust Noise at 1m Horizontally from Centerline of Exhaust Pipe dista (without Fan)	dB(A)	98.3	100.7	98.3	100.7

The all data and the specific fuel consumption are based on ISO 3046/1, Standard reference conditions are in accordance with 298 K(25° Celsius) air temperature, 100kPa(1000mbar) air pressure, 60% relative humidity, 110m(361ft) altitude.

Operation At Elevated Temperature And Altitude: The engine may be operated at :

1800 rpm & 1500rpm up to 750~ 1000m and 30°C without power deration

For sustained operation above these conditions, derate by 3% per 304m , and 2% per 11 °C

Engine Data with Dry Type Exhaust Manifold

○ Intake Air Flow	m3/min	15.71	22.33	16.95	23.35
○ Exhaust gas temp. after turbo.	°C	-	509	580	524
○ Exhaust Gas Flow	m3/min	-	40.9	33.9	44.6
○ Heat Rejection to Exhaust	kW	151.9	178.3	170.6	200.2
○ Heat Rejection to Coolant	kW	66.0	77.5	74.2	87.0
○ Heat Rejection to Intercooler	kW	35.2	41.3	39.5	46.4
○ Radiated Heat to Ambient	kW	15.4	18.1	17.3	20.3
○ Cooling water circulation	liters/min	130	150	130	150
○ Cooling fan air flow	m3/min	190	224	190	224

◆ ENGINE DIMENSION

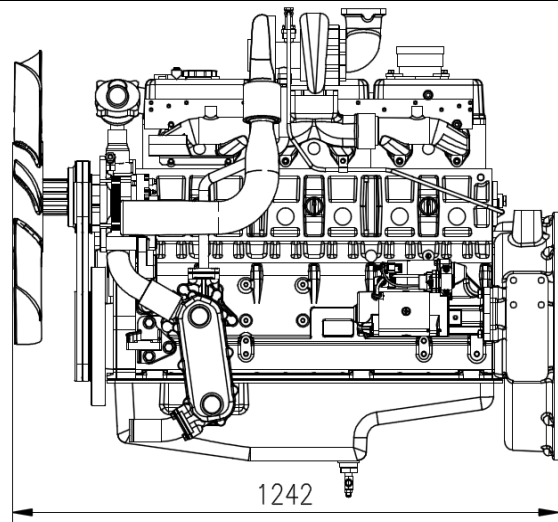
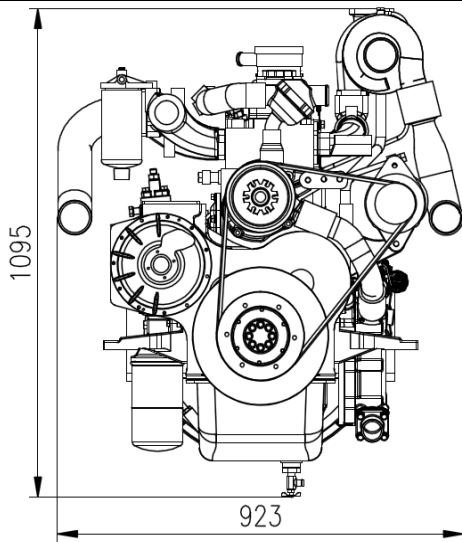

◆ CONVERSION TABLE

in. = mm x 0.0394

PS = kW x 1.3596

psi = kg/cm² x 14.2233

in³ = lit. x 61.02

hp = PS x 0.98635

lb = kg x 2.20462

kW = Kcal/sec x 0.239

lb/ft = N.m x 0.737

U.S. gal = lit. x 0.264

kW = 0.2388 kcal/s

lb/PS.h = g/kW.h x 0.00162

cfm = m³/min x 35.336

Mpa = Pa x 1000 = bar x 10

Doosan Infracore Co., Ltd.

21st Floor, Doosan Tower, 18-12, Euljiro 6-ga,
Jung-gu, Seoul, Korea

TEL : +82-2-3398-8400 / Fax : +82-2-3398-8509

E-mail : enginesales@doosan.com

Web site : www.doosaninfracore.com

※ Specifications are subject to change without prior notice