

## DATA SHEET

DIESEL GENERATOR 176KW  
 MODEL#FDK-P176/H1  
 50HZ/1500RPM  
 PERKINS MODEL: 1106A-70TAG4

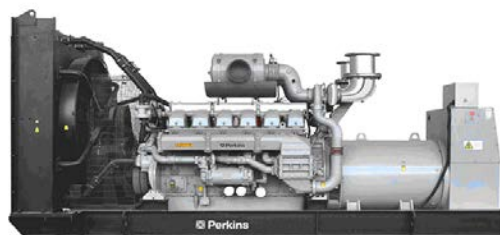

### General Features:

- ◆ All qualified generator sets are subjected to a comprehensive performance test which includes 50% load, 70% load, 100% load, 110% load and to check, verify that all control systems, alarm and shut-down protection.
- ◆ Equipped with battery charger and 24V high performance maintenance-free lead-acid starting batteries and connecting cables.
- ◆ Stainless galvanized zinc plates with strong corrosion-proof.
- ◆ Vibration isolators between the engine/alternator and base frame.
- ◆ Equipped with industrial silencer and flexible exhaust hose.
- ◆ Designed to comply with ISO8528/GB2820.
- ◆ Powered by Perkins engine and coupled with Stamford alternator.
- ◆ Water jacket preheater, oil heater and double air cleaner, etc. are available.

### FDK Diesel Generator Set Data

Genset Model	FDK-P176/H1
Prime Power	160KW/200KVA
Standby Power	176KW/220KVA
Output Frequency / Rated speed	50Hz/1500rpm
Rated Voltage	230V/400V

Engine Make	Perkins CHINA
Engine Model	1106A-70TAG4
Alternator model	Stamford UCI274H
Control System	DSE7320
Phase	Three

(1) **Prime power:** The rating is available for an unlimited of annual operating hours in variable load applications, in accordance with ISO8528-1.A 10% overload is available for a period of 1 hour within 12-hour period of operation, in accordance with ISO 3046-1.

(2) **Standby power:** The rating is applicable for supplying emergency power in variable load applications for up to 200 hours per year in accordance with ISO8528-1. Overload is not allowed.

(3) **Rated voltage:** available with customer requirement.

### Engine Specifications (DETAILED in APPENDIX)

Engine Model	1106A-70TAG4
Engine Manufacturer	Perkins CHINA
Cylinder quantity	6
Cylinder Arrangement	In-line
Cycle	4
Aspiration	Turbo charged

Bore x Stroke (mm x mm)	105x135
Displacement	7.01L
Compression Ratio	16:1
Prime power / Speed (KW/RPM)	178.9kw/1500
Standby power/ Speed (KW/RPM)	196.3kw/1500
Governor type	N.A.



ISO9001:2008

FDK reserves the right to change the specifications and designs without notice.

Piston Speed	N.A.
ElectropaK net engine power	N.A.
Total Lubrication System Capacity (L)	16.5
Total Coolant Capacity (L)	21

Fuel Consumption at 100% load (L/HOUR)	N.A.
Starter motor	N.A.
Alternator	N.A.
Minimum cranking speed.	N.A.

## Alternator Specifications

Alternator model	UCI274H
Alternator manufacturer	STAMFORD
Exciter type	Single bearing, Brushless, Self-excited
Rated output prime power	200KVA
Rated speed	1500 rpm
Rated frequency	50Hz

Number of phase	3
Rated voltage	400V (Available with custom requirements)
Power factor	0.8
Voltage regulation NL-FL	≤±1%
Insulation grade	H
Protection grade	IP23

**Alternator option: Leroy Somer, MECC, Marathon, Engga, Faraday**

## Control System DSE7320 (DETAILED in INSTRUCTION)

DSE7320 is an advanced control module based on micro-processor, containing all necessary functions for protection of the genset and the breaker control. It can monitor the mains supply, breaker control and automatically start the engine when the mains are abnormal. Accurately measure various operational parameters and display all values and alarms information on the LCD. In addition, the control module can automatically shut down the engine and indicate the engine failure.

### FEATURES

- ♦ Microprocessor control, with high stability and credibility.
- ♦ Monitoring and measuring operational parameters of the mains supply and genset.
- ♦ Indicating operation status, fault conditions, all parameters and alarms.
- ♦ Multiple protections; multiple parameters display, like pressure, temp. etc.
- ♦ Manual, automatic and remote work mode selectable.
- ♦ Real time clock for time and date display, overall runtime display, 250 log entries.
- ♦ Overall power output display.
- ♦ Integral speed/frequency detecting, telling status of start, rated operation, overspeed etc.
- ♦ Communication with PC via RS485 OR RS232 interface, using MODBUS protocol.

## Soundproof Enclosure Specification

FDK silent generator is designed by professional acoustic engineers based on years of experience. Now we can make the noise of the generator less than 80-85dB(A) at 1m, or 70-75dB(A) at 7m, 60-65dB(A) at 15m.

### FEATURES

- ♦ Multi-way air intake and exhaust guarantee the power performance of the generator.
- ♦ Large-scale impedance combined type silencer effectively reduce noise of the generator.
- ♦ Internal high performance rubber damper and flexible materials reduce vibration.
- ♦ Base mounted fuel tank supports the generator running for 8 hours.

## Optional



ISO9001:2008

FDK reserves the right to change the specifications and designs without notice.

Generator set	Alternator	Low environment Temp	ATS
<input type="checkbox"/> Open generator set <input type="checkbox"/> Silent generator set <input type="checkbox"/> Trailer generator set <input type="checkbox"/> ABB MCCB circuit breaker	<input type="checkbox"/> Stamford <input type="checkbox"/> Marathon <input type="checkbox"/> Mecc Alte <input type="checkbox"/> Leroy Somer <input type="checkbox"/> Farady <input type="checkbox"/> Engga	<input type="checkbox"/> Water heater <input type="checkbox"/> Oil heater <input type="checkbox"/> Battery heater	<input type="checkbox"/> CHINT <input type="checkbox"/> SCHNEIDER <input type="checkbox"/> ABB
Fuel system	Control system	Voltage	Synchronized system
<input type="checkbox"/> 12hrs base tank <input type="checkbox"/> 24hrs base tank <input type="checkbox"/> Dual wall base fuel tank <input type="checkbox"/> Outside fuel tank	<input type="checkbox"/> AMF function <input type="checkbox"/> ATS control cabinet <input type="checkbox"/> DSE7320 <input type="checkbox"/> DSE7510 <input type="checkbox"/> GU620A	<input type="checkbox"/> 415/240V <input type="checkbox"/> 400/230V <input type="checkbox"/> 380/220V <input type="checkbox"/> 220/127V <input type="checkbox"/> 200/115V	<input type="checkbox"/> CHINT Cabinet <input type="checkbox"/> SCHNEIDER Cabinet <input type="checkbox"/> DSE8610 Module <input type="checkbox"/> COMAQ Module <input type="checkbox"/> DEIF Module

## Dimension & Weight

### Open

Overall Size: LxWxH (mm)	2400x900x1500
Weight (kg)	1500

### Soundproof Version

Overall Size: LxWxH (mm)	3150x1300x2000
Weight (kg)	2600

## Sales Promises

- ◆ FDK provides a full line of brand new and high quality products. Each and every unit is strictly factory tested before shipment.
- ◆ Quality warranty is according to our standard conditions: 12 months from BL date or 1000 running hours, whichever comes first.
- ◆ Service and parts are available from FDK or distributors in your location.
- ◆ FDK guarantee use **BRAND NEW & GENUINE MACHINE.**



# 1100 Series 1106A-70TAG4 Diesel Engine – Electropak

200 kVA Prime Power / 220 kVA Standby Power

Building upon Perkins proven reputation within the power generation industry, the 1100 Series range of Electropak engines now fit even closer to customers needs.

In the world of power generation success is only gained by providing more for less. With the 1106A-70TAG Perkins has engineered even higher levels of reliability, yet lowered the cost of ownership.

1100A units are designed for territories that do not require compliance to EPA or EU emissions legislation. These engines are assembled around optimal, efficient manufacturing processes with state-of-the-art technology. They are built to provide the exact power solution for customers who sell their applications into lesser regulated countries.

Focusing on our common platform theme, changes to engine envelope dimensions and connection points have been kept to a minimum.



## Dependable power

- The Perkins 1106A-70TAG delivers up to 220 kVA standby at 50 Hz, providing greater productivity through an improved power to weight ratio
- This world-class power density has been achieved in a 7 litre engine, using a mechanical fuel injection system; making this engine robust for all markets, with the ability to cope with the variation of fuel qualities around the world

The 1106A has been designed for excellent load acceptance to ensure your facility is powered quickly at all conditions

## Low operating costs

- Service intervals are set at 500 hours as standard.
- Perkins provides comprehensive warranty cover for two years (up to 3,000 hours), with three years on major engine components
- A low usage warranty package is also available

## World class product support

- Through an experienced global network of distributors and dealers, fully trained engine experts deliver total service support around the clock, 365 days a year. They have a comprehensive suite of web based tools at their finger tips, covering technical information, parts identification and ordering systems, all dedicated to maximising the productivity of your engine
- Perkins actively pursues product support excellence by insisting our distribution network invest in their territory to provide you with a consistent quality of support across the globe
- Throughout the entire life of a Perkins engine, we provide access to genuine OE specification parts giving 100% reassurance that you receive the very best in terms of quality for lowest possible cost... wherever your Perkins powered machine is operating in the world

Discover more

[www.perkins.com](http://www.perkins.com)

[www.perkins.com/esc](http://www.perkins.com/esc)

[www.perkins.com/distributor](http://www.perkins.com/distributor)

To find your local distributor

Engine Speed rpm	Type of Operation	Typical Generator Output (Net)		Engine Power			
				Gross		Net	
		kVA	kWe	kWm	hp	kWm	hp
1500	Prime Power	200	160	178.9	240	173.9	240
	Standby (maximum)	220	176	196.3	263	191.3	256

Photographs are for illustrative purposes only and may not reflect final specification.

All information in this document is substantially correct at time of printing and may be altered subsequently.  
Publication No. PN1975/08/13 Produced in England ©2013 Perkins Engines Company Limited

 **Perkins**<sup>®</sup>

THE HEART OF EVERY GREAT MACHINE

# 1100 Series 1106A-70TAG4 Diesel Engine – ElectropaK

200 kVA Prime Power / 220 kVA Standby Power

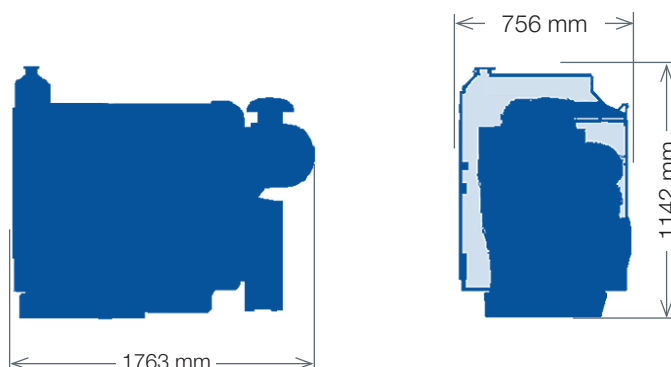

## Engine specification

- Tropical radiator pipes and guards
- Flywheel housing
- Flywheel and starter ring
- Oil filters
- Starter motor
- Air cleaners and brackets
- Lubricating oil sump
- Alternator
- Induction manifolds
- Exhaust manifolds
- Fuel filter
- Cold start aid
- Engine mountings

## Engine data

Number of cylinders .....	Vertical in-line 6 cylinder
Bore and stroke.....	105 x 135 mm (4.13 x 5.31 in)
Displacement .....	7.01 litres (428 in <sup>3</sup> )
Aspiration .....	Turbocharged aftercooled
Cycle.....	4 stroke
Combustion system.....	Direct injection
Compression ratio .....	16:1
Engine rotation .....	Anti-clockwise viewed on flywheel
Cooling system.....	Liquid
Total lubrication capacity.....	16.5 litres (4.36 US gal)
Total coolant capacity .....	21 litres (5.5 US gal)
Dimensions – Length .....	1763 mm (69.4 in) with air cleaner
Width .....	756 mm (29.8 in)
Height .....	1142 mm (45 in)
Dry weight .....	788 kg (1737 lbs)
Final weight and dimensions will depend on completed specification	

Photographs are for illustrative purposes only and may not reflect final specification.

All information in this document is substantially correct at time of printing and may be altered subsequently.  
Publication No. PN1975/08/13 Produced in England  
©2013 Perkins Engines Company Limited

## Perkins Engines Company Limited

Peterborough PE1 5FQ  
United Kingdom  
Telephone +44 (0)1733 583000  
Fax +44 (0)1733 582240  
[www.perkins.com](http://www.perkins.com)



THE HEART OF EVERY GREAT MACHINE

[www.fdkenergy.com](http://www.fdkenergy.com)