

DATA SHEET

DIESEL GENERATOR 72KW

MODEL#FDK-D72/H1

50HZ/1500RPM

DOOSAN MODEL: D1146



General Features:

- ♦ All qualified generator sets are subjected to a comprehensive performance test which includes 50% load, 70% load, 100% load, 110% load and to check, verify that all control systems, alarm and shut-down protection.
- ♦ Equipped with battery charger and 24V high performance maintenance-free lead-acid starting batteries and connecting cables.
- ♦ Stainless galvanized zinc plates with strong corrosion-proof.
- ♦ Vibration isolators between the engine/alternator and base frame.
- ♦ Equipped with industrial silencer and flexible exhaust hose.
- ♦ Designed to comply with ISO8528/GB2820.
- ♦ Powered by Doosan engine and coupled with Stamford alternator.
- ♦ Water jacket preheater, oil heater and double air cleaner, etc. are available.

FDK Diesel Generator Set Data

Genset Model	FDK-D72/H1
Prime Power	66KW/83KVA
Standby Power	72KW/90KVA
Output Frequency / Rated speed	50Hz/1500rpm
Rated Voltage	230V/400V

Engine Make	Doosan Korea
Engine Model	D1146
Alternator model	Stamford UCI224G
Control System	DSE7320
Phase	Three

(1) **Prime power:** The rating is available for an unlimited of annual operating hours in variable load applications, in accordance with ISO8528-1.A 10% overload is available for a period of 1 hour within 12-hour period of operation, in accordance with ISO 3046-1.

(2) **Standby power:** The rating is applicable for supplying emergency power in variable load applications for up to 200 hours per year in accordance with ISO8528-1. Overload is not allowed.

(3) **Rated voltage:** available with customer requirement.

Engine Specifications (DETAILED in APPENDIX)

Engine Model	D1146
Engine Manufacturer	Doosan (Korea)
Cylinder quantity	6
Cylinder Arrangement	In-line
Cycle	Four stroke
Aspiration	Naturally

Bore x Stroke (mm x mm)	111x139
Displacement	8.071L
Compression Ratio	17.5:1
Prime power / Speed (KW/RPM)	77/1500
Standby power/ Speed (KW/RPM)	85/1500
Speed governor	RSV



ISO9001:2008

FDK reserves the right to change the specifications and designs without notice.

Piston Speed	6.95m/s
Friction Energy Output	18kw
Total Lubrication System Capacity (L)	15.5
Coolant Capacity (L)	14

Fuel Consumption at 100% load (liters/hr)	20.6 at 1500rpm
Starter motor	DC24V
Alternator	DC24V
Low idle	800-1650RPM

Alternator Specifications

Alternator model	UCI224G
Alternator manufacturer	STAMFORD
Exciter type	Single bearing, Brushless, Self-excited
Rated output prime power	85 KVA
Rated speed	1500 rpm
Rated frequency	50Hz

Number of phase	3
Rated voltage	400V (Available with custom requirements)
Power factor	0.8
Voltage regulation NL-FL	≤±1%
Insulation grade	H
Protection grade	IP23

Alternator option: Leroy Somer, MECC, Marathon, Engga, Faraday

Control System DSE7320 (DETAILED in INSTRUCTION)

DSE7320 is an advanced control module based on micro-processor, containing all necessary functions for protection of the genset and the breaker control. It can monitor the mains supply, breaker control and automatically start the engine when the mains are abnormal. Accurately measure various operational parameters and display all values and alarms information on the LCD. In addition, the control module can automatically shut down the engine and indicate the engine failure.

FEATURES

- ◆ Microprocessor control, with high stability and credibility.
- ◆ Monitoring and measuring operational parameters of the mains supply and genset.
- ◆ Indicating operation status, fault conditions, all parameters and alarms.
- ◆ Multiple protections; multiple parameters display, like pressure, temp. etc.
- ◆ Manual, automatic and remote work mode selectable.
- ◆ Real time clock for time and date display, overall runtime display, 250 log entries.
- ◆ Overall power output display.
- ◆ Integral speed/frequency detecting, telling status of start, rated operation, overspeed etc.
- ◆ Communication with PC via RS485 OR RS232 interface, using MODBUS protocol.

Soundproof Enclosure Specification

FDK silent generator is designed by professional acoustic engineers based on years of experience. Now we can make the noise of the generator less than 80-85dB(A) at 1m, or 70-75dB(A) at 7m, 60-65dB(A) at 15m.

FEATURES

- ◆ Multi-way air intake and exhaust guarantee the power performance of the generator.
- ◆ Large-scale impedance combined type silencer effectively reduce noise of the generator.
- ◆ Internal high performance rubber damper and flexible materials reduce vibration.
- ◆ Base mounted fuel tank supports the generator running for 8 hours.



ISO9001:2008

FDK reserves the right to change the specifications and designs without notice.

Optional

Generator set	Alternator	Low environment Temp	ATS
<input type="checkbox"/> Open generator set <input type="checkbox"/> Silent generator set <input type="checkbox"/> Trailer generator set <input type="checkbox"/> ABB MCCB circuit breaker	<input type="checkbox"/> Stamford <input type="checkbox"/> Marathon <input type="checkbox"/> Mecc Alte <input type="checkbox"/> Leroy Somer <input type="checkbox"/> Farady <input type="checkbox"/> Engga	<input type="checkbox"/> Water heater <input type="checkbox"/> Oil heater <input type="checkbox"/> Battery heater	<input type="checkbox"/> CHINT <input type="checkbox"/> SCHNEIDER <input type="checkbox"/> ABB
Fuel system	Control system	Voltage	Synchronized system
<input type="checkbox"/> 12hrs base tank <input type="checkbox"/> 24hrs base tank <input type="checkbox"/> Dual wall base fuel tank <input type="checkbox"/> Outside fuel tank	<input type="checkbox"/> AMF function <input type="checkbox"/> ATS control cabinet <input type="checkbox"/> DSE7320 <input type="checkbox"/> DSE7510 <input type="checkbox"/> GU620A	<input type="checkbox"/> 415/240V <input type="checkbox"/> 400/230V <input type="checkbox"/> 380/220V <input type="checkbox"/> 220/127V <input type="checkbox"/> 200/115V	<input type="checkbox"/> CHINT Cabinet <input type="checkbox"/> SCHNEIDER Cabinet <input type="checkbox"/> DSE8610 Module <input type="checkbox"/> COMAQ Module <input type="checkbox"/> DEIF Module

Dimension & Weight

Open

Overall Size: LxWxH (mm)	2150x750x1180
Weight (kg)	1260

Soundproof Version

Overall Size: LxWxH (mm)	3300x1100x1900
Weight (kg)	1900

Sales Promises

- ◆ FDK provides a full line of brand new and high quality products. Each and every unit is strictly factory tested before shipment.
- ◆ Quality warranty is according to our standard conditions: 12 months from BL date or 1000 running hours, whichever comes first.
- ◆ Service and parts are available from FDK or distributors in your location.
- ◆ FDK guarantee use **BRAND NEW & GENUINE MACHINE.**



D1146 G-DRIVE

◎ POWER RATING

Engine Speed rev/min	Type of Operation	Engine Power	
		kWm	Ps
1800	Prime Power	96	130
	Standby Power	105	143
1500	Prime Power	77	105
	Standby Power	85	116



- The engine performance corresponds to ISO 3046, BS 5514 and DIN 6271.
- Ratings are based on ISO 8528. (If you need more information, contact the sales organization.)
 - **Prime power** is available for an unlimited number of hours per year in a variable load application.
The permissible average power output over 24 hours of operation shall not exceed 70% of the prime power rating.
 - **Standby power** is available in the event of a utility power outage or under test conditions for up to 200h of operation per year.
The permissible average power output over 24 hours of operation shall not exceed 70% of the standby power rating.
No overload is permitted.

◎ MECHANICAL SYSTEM

- Engine Model D1146
- Engine Type In-line 4 cycle, water cooled
Naturally aspirated
- Combustion type Direct injection
- Cylinder Type Replaceable dry liner
- Number of cylinders 6
- Bore x stroke 111(4.37) x 139(5.47) mm(in.)
- Displacement 8.071(492.49) lit.(in3)
- Compression ratio 17.5 : 1
- Firing order 1-5-3-6-2-4
- Injection timing 15° BTDC
- Compression pressure Above 28 kg/cm²(398 psi) at 200rpm
- Dry weight Approx. 720 kg (1,587 lb)
- Dimension (LxWxH) 1,224 x 727 x 973 mm
(48.2 x 28.6 x 38.3 in.)
- Rotation Counter clockwise viewed from Flywheel
- Fly wheel housing SAE NO.2
- Fly wheel Clutch NO.11 1/2

◎ MECHANISM

- Type Over head valve
- Number of valve Intake 1, exhaust 1 per cylinder
- Valve lashes at cold Intake 0.30 mm (0.0118 in.)
Exhaust 0.30 mm (0.0118 in.)

◎ VALVE TIMING

- | | Opening | Close |
|-----------------|--------------|--------------|
| ○ Intake valve | 16 deg. BTDC | 36 deg. ABDC |
| ○ Exhaust valve | 46 deg. BBDC | 14 deg. ATDC |

◎ FUEL CONSUMPTION

- | ○ Prime Power (lit/hr) | 1,500 rpm | 1,800 rpm |
|--------------------------|-----------|-----------|
| 25% | 7.5 | 8.9 |
| 50% | 11.3 | 13.6 |
| 75% | 15.9 | 19.0 |
| 100% | 20.6 | 24.7 |
| ○ Standby Power (lit/hr) | 1,500 rpm | 1,800 rpm |
| 25% | 7.7 | 9.2 |
| 50% | 11.6 | 14.9 |
| 75% | 16.1 | 20.8 |
| 100% | 20.8 | 26.6 |

◎ FUEL SYSTEM

- Injection pump Zexel in-line “AD” type
- Governor RSV type (all speed control)
- Feed pump Mechanical type
- Injection nozzle Multi hole type
- Opening pressure 214 kg/cm² (3,044 psi)
- Fuel filter Full flow, cartridge type
- Used fuel Diesel fuel oil

◎ LUBRICATION SYSTEM

- Lub. Method Fully forced pressure feed type
- Oil pump Gear type driven by crankshaft
- Oil filter Full flow, cartridge type
- Oil pan capacity High level 15.5 liters (4.09 gal.)
Low level 12 liters (3.17 gal.)
- Angularity limit Front down 25 deg.
Front up 25 deg.
Side to side 25 deg.
- Lub. Oil Refer to Operation Manual

D1146 G-DRIVE

◎ COOLING SYSTEM

- Cooling method Fresh water forced circulation
- Water capacity 14 liters (3.70 gal.)
(engine only)
- Pressure system Max. 0.5 kg/cm² (7.11 psi)
- Water pump Centrifugal type driven by belt
- Water pump Capacity 150 liters (39.6 gal.)/min
at 1,800 rpm (engine)
- Thermostat Wax – pellet type
Opening temp. 71°C
Full open temp. 85°C
- Cooling fan Blower type, steel
590 mm diameter, 6 blade

◎ ELECTRICAL SYSTEM

- Charging generator 24V x 45A alternator
- Voltage regulator Built-in type IC regulator
- Starting motor 24V x 4.5kW
- Battery Voltage 24V
- Battery Capacity 100 AH (recommended)
- Starting aid (Option) Block heater

◎ ENGINEERING DATA

- Water flow 130 liters/min @1,500 rpm
- Heat rejection to coolant
- Air flow 5.8 m³/min @1,500 rpm
- Exhaust gas flow
- Exhaust gas temp.

- Water flow 150 liters/min @1,800 rpm
- Heat rejection to coolant 16.5 kcal/sec @1,800 rpm
- Air flow 6.9 m³/min @1,800 rpm
- Exhaust gas flow 18.8 m³/min @1,800 rpm
- Exhaust gas temp. 620 °C @1,800 rpm

- Max. permissible restrictions
 - .Intake system 220 mmH₂O initial
635 mmH₂O final
 - .Exhaust system 1,000 mmH₂O max.
- Max. permissible altitude 800 m

◆ CONVERSION TABLE

- | | |
|------------------------------------|------------------------------------|
| in. = mm x 0.0394 | lb/ft = N.m x 0.737 |
| PS = kW x 1.3596 | U.S. gal = lit. x 0.264 |
| psi = kg/cm ² x 14.2233 | kW = 0.2388 kcal/s |
| in ³ = lit. x 61.02 | lb/PS.h = g/kW.h x 0.00162 |
| hp = PS x 0.98635 | cfm = m ³ /min x 35.336 |
| lb = kg x 2.20462 | |

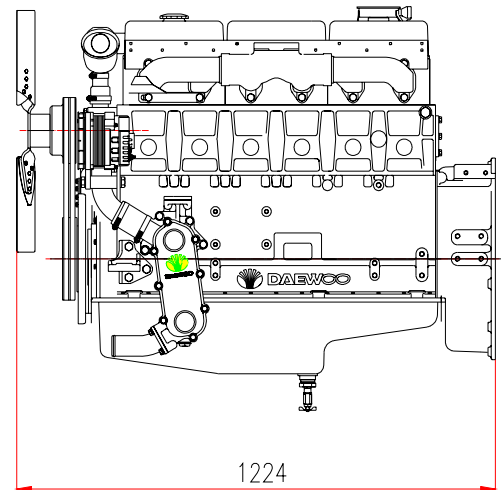
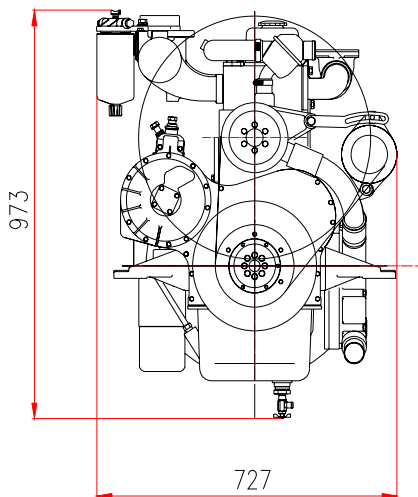

Head office
7-11, Hwasu-Dong, Dong-Gu, Incheon, Korea
TEL : 82-32-211-2246, 2222 FAX : 82-32-761-2759

Seoul Office
Doosan Infracore Co. Ltd.,
22nd Floor, Doosan Tower, 18-12, Euljiro 6-ga, Jung-gu,
Seoul, Korea.
TEL : 82-2-3398-8521~8535 FAX : 82-2-3398-8509
Web site : www.doosaninfracore.com

※ Specifications are subject to change without prior notice