

DATA SHEET

DIESEL GENERATOR 440KW

MODEL#FDK-D440/H1

50HZ/1500RPM

DOOSAN MODEL: DP158LD

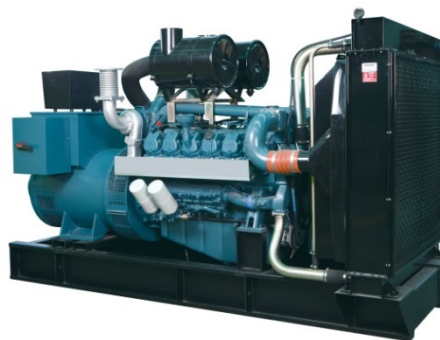

General Features:

- ♦ All qualified generator sets are subjected to a comprehensive performance test which includes 50% load, 70% load, 100% load, 110% load and to check, verify that all control systems, alarm and shut-down protection.
- ♦ Equipped with battery charger and 24V high performance maintenance-free lead-acid starting batteries and connecting cables.
- ♦ Stainless galvanized zinc plates with strong corrosion-proof.
- ♦ Vibration isolators between the engine/alternator and base frame.
- ♦ Equipped with industrial silencer and flexible exhaust hose.
- ♦ Designed to comply with ISO8528/GB2820.
- ♦ Powered by Doosan engine and coupled with Stamford alternator.
- ♦ Water jacket preheater, oil heater and double air cleaner, etc. are available.

FDK Diesel Generator Set Data

Genset Model	FDK-D440/H1
Prime Power	400KW/500KVA
Standby Power	440KW/550KVA
Output Frequency / Rated speed	50Hz/1500rpm
Rated Voltage	230V/400V

Engine Make	Doosan Korea
Engine Model	DP158LD
Alternator model	Stamford HCI544D
Control System	DSE7320
Phase	Three

(1) **Prime power:** The rating is available for an unlimited of annual operating hours in variable load applications, in accordance with ISO8528-1.A 10% overload is available for a period of 1 hour within 12-hour period of operation, in accordance with ISO 3046-1.

(2) **Standby power:** The rating is applicable for supplying emergency power in variable load applications for up to 200 hours per year in accordance with ISO8528-1. Overload is not allowed.

(3) **Rated voltage:** available with customer requirement.

Engine Specifications (DETAILED in APPENDIX)

Engine Model	DP158LD
Engine Manufacturer	Doosan (Korea)
Cylinder quantity	8
Cylinder Arrangement	V-type
Cycle	Four stroke
Aspiration	Turbo charged

Bore x Stroke (mm x mm)	128x142
Displacement	14.618L
Compression Ratio	15:1
Prime power / Speed (KW/RPM)	464/1500
Standby power/ Speed (KW/RPM)	510/1500
Speed governor	Electric type



ISO9001:2008

FDK reserves the right to change the specifications and designs without notice.

Piston Speed	7.1m/s
Friction Energy Output	32kw
Total Lubrication System Capacity (L)	22
Coolant Capacity (L)	20

Fuel Consumption at 100% load (liters/hr)	115.1 at 1500rpm
Starter motor	24V
Alternator	24V
Low idle	800-1650RPM

Alternator Specifications

Alternator model	HCI544D
Alternator manufacturer	STAMFORD
Exciter type	Single bearing, Brushless, Self-excited
Rated output prime power	500 KVA
Rated speed	1500 rpm
Rated frequency	50Hz

Number of phase	3
Rated voltage	400V (Available with custom requirements)
Power factor	0.8
Voltage regulation NL-FL	±1%
Insulation grade	H
Protection grade	IP23

Alternator option: Leroy Somer, MECC, Marathon, Engga, Faraday

Control System DSE7320 (DETAILED in INSTRUCTION)

DSE7320 is an advanced control module based on micro-processor, containing all necessary functions for protection of the genset and the breaker control. It can monitor the mains supply, breaker control and automatically start the engine when the mains are abnormal. Accurately measure various operational parameters and display all values and alarms information on the LCD. In addition, the control module can automatically shut down the engine and indicate the engine failure.

FEATURES

- ♦ Microprocessor control, with high stability and credibility.
- ♦ Monitoring and measuring operational parameters of the mains supply and genset.
- ♦ Indicating operation status, fault conditions, all parameters and alarms.
- ♦ Multiple protections; multiple parameters display, like pressure, temp. etc.
- ♦ Manual, automatic and remote work mode selectable.
- ♦ Real time clock for time and date display, overall runtime display, 250 log entries.
- ♦ Overall power output display.
- ♦ Integral speed/frequency detecting, telling status of start, rated operation, overspeed etc.
- ♦ Communication with PC via RS485 OR RS232 interface, using MODBUS protocol.

Soundproof Enclosure Specification

FDK silent generator is designed by professional acoustic engineers based on years of experience. Now we can make the noise of the generator less than 80-85dB(A) at 1m, or 70-75dB(A) at 7m, 60-65dB(A) at 15m.

FEATURES

- ♦ Multi-way air intake and exhaust guarantee the power performance of the generator.
- ♦ Large-scale impedance combined type silencer effectively reduce noise of the generator.
- ♦ Internal high performance rubber damper and flexible materials reduce vibration.
- ♦ Base mounted fuel tank supports the generator running for 8 hours.



ISO9001:2008

FDK reserves the right to change the specifications and designs without notice.

Optional

Generator set	Alternator	Low environment Temp	ATS
<input type="checkbox"/> Open generator set <input type="checkbox"/> Silent generator set <input type="checkbox"/> Trailer generator set <input type="checkbox"/> ABB MCCB circuit breaker	<input type="checkbox"/> Stamford <input type="checkbox"/> Marathon <input type="checkbox"/> Mecc Alte <input type="checkbox"/> Leroy Somer <input type="checkbox"/> Farady <input type="checkbox"/> Engga	<input type="checkbox"/> Water heater <input type="checkbox"/> Oil heater <input type="checkbox"/> Battery heater	<input type="checkbox"/> CHINT <input type="checkbox"/> SCHNEIDER <input type="checkbox"/> ABB
Fuel system	Control system	Voltage	Synchronized system
<input type="checkbox"/> 12hrs base tank <input type="checkbox"/> 24hrs base tank <input type="checkbox"/> Dual wall base fuel tank <input type="checkbox"/> Outside fuel tank	<input type="checkbox"/> AMF function <input type="checkbox"/> ATS control cabinet <input type="checkbox"/> DSE7320 <input type="checkbox"/> DSE7510 <input type="checkbox"/> GU620A	<input type="checkbox"/> 415/240V <input type="checkbox"/> 400/230V <input type="checkbox"/> 380/220V <input type="checkbox"/> 220/127V <input type="checkbox"/> 200/115V	<input type="checkbox"/> CHINT Cabinet <input type="checkbox"/> SCHNEIDER Cabinet <input type="checkbox"/> DSE8610 Module <input type="checkbox"/> COMAQ Module <input type="checkbox"/> DEIF Module

Dimension & Weight

Open

Overall Size: LxWxH (mm)	3250x1380x1870
Weight (kg)	3110

Soundproof Version

Overall Size: LxWxH (mm)	4300x1600x2300
Weight (kg)	3800

Sales Promises

- ◆ FDK provides a full line of brand new and high quality products. Each and every unit is strictly factory tested before shipment.
- ◆ Quality warranty is according to our standard conditions: 12 months from BL date or 1000 running hours, whichever comes first.
- ◆ Service and parts are available from FDK or distributors in your location.
- ◆ FDK guarantee use **BRAND NEW & GENUINE MACHINE.**



DOOSAN INFRACORE GENERATOR ENGINE

DP158LD

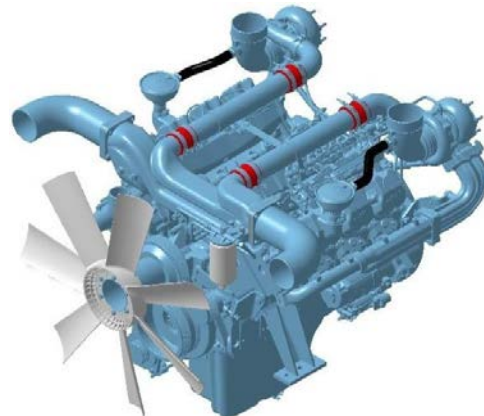

Ratings (kWm/PS)	Gross Engine Output - without Cooling Fan		Net Engine Output - with Cooling Fan	
	Standby	Prime	Standby	Prime
1500rpm(50Hz)	510/693	464/630	494/672	448/609
1800rpm(60Hz)	556/756	505/687	532/750	481/654

* 50Hz : DP158LDF, 60Hz : DP158LDS

Ratings Definitions

The power ratings of Emergency Standby and Prime are in accordance with ISO 8528.

Fuel Stop power in accordance with ISO 3046.

Electric power(kWe) should be estimated by considering generator efficiency, cooling fan power loss and power derating due to altitude and ambient temperature.

STANDBY POWER RATING is applicable for supplying emergency power for the duration of the utility power outage.

No overload capability is available for this rating. A standby rated engine should be sized for a maximum of an 70% average load factor and 200 hours of operation per year. This includes less than 25 hours per year at the Standby Power rating.

PRIME POWER RATING is available for an unlimited of hours per year in variable load application. Variable load should not exceed a 70% average of the Prime Power rating during any operating period of 24 hours. The Total operating time at 100% Prime Power shall not exceed 500 hours per year. A 10% overload capability is available for a period of 1 hour within a 12 hour period of operation. Total operating time at the 10% overload power shall not exceed 25 hours per year.

◎ GENERAL ENGINE DATA

○ Engine Model	DP158LD
○ Engine Type	4-Cycle, V-type, 8-Cylinder, Turbo charged & intercooled (air to air)
○ Bore x stroke	128 x 142 mm
○ Displacement	14.618 liters
○ Compression ratio	15 : 1
○ Rotation	Counter clockwise viewed from Flywheel
○ Firing order	1-5-7-2-6-3-4-8
○ Injection timing	23°±1° BTDC @ 1800 rpm, 18°±1° BTDC @ 1500 rpm,
○ Dry weight	1155 kg (with fan)
○ Dimension (LxWxH)	1,274 x 1,138 x 1,207 mm
○ Fly wheel housing	SAE NO.1M
○ Fly wheel	Clutch NO.14M
○ Number of teeth on flywheel	160

◎ ENGINE MOUNTING

○ Maximum Bending Moment at Rear Face to Block	1,325 N.m
--	-----------

◎ EXHAUST SYSTEM

○ Maximum Back Pressure	5.9 kPa
-------------------------	---------

◎ AIR INDUCTION SYSTEM

○ Maximum Intake Air Restriction	
. With Clean Filter Element	2.16 kPa
. With Dirty Filter Element	6.23 kPa
○ Max. static pressure after Radiator	0.125 kPa

◎ COOLING SYSTEM

Water circulation by centrifugal pump on engine.

○ Cooling method	Fresh water forced circulation
○ Coolant capacity	Engine Only : Approx. 20 lit, With Radiator(*Air On 43°C) : Approx 79 lit.
○ Coolant flow rate	660 liters / min @ 1800 rpm, 550 liters / min @ 1500 rpm,
○ Pressure Cap	Max. 49 kPa
○ Water Temperature	
- Maximum for standby and Prime	103°C
- Before start of full load	40.0°C
○ Water pump	Centrifugal type driven by belt
○ Thermostat Type and Range	Wax – pellet type, Opening temp. 71°C , Full open temp. 85°C
○ Cooling fan	Blower type, plastic , 915 mm diameter, 7 blade
○ Max. external coolant system restriction	Not available

* Two radiator options are provided, based on allowable maximum Air temperature On radiator inlet (Air On) : Air On 43°C / Air On 52°C
- ATB(Ambient Temperature before Boiling) of generator set varies depending on the engine room ventilation design, even if the same radiator applied.
Adequate selection of radiator options by means of the cooling test is highly recommended, and generator set makers are responsible for the selection.

◎ LUBRICATION SYSTEM

Force-feed lubrication by gear pump, lubricating oil cooling in cooling water circuit of engine.

○ Lub. Method	Fully forced pressure feed type
○ Oil pump	Gear type driven by crank-shaft gear
○ Oil filter	Full flow, cartridge type
○ Oil capacity	Max. 22 liters , Min. 13 liters
○ Lub oil pressure	Idle Speed : Min 100 kPa Governed Speed : Min 250 kPa
○ Maximum oil temperature	120°C
○ Angularity limit	Front down 10 deg , Front up 10 deg , Side to side 22.5 deg
○ Lubrication oil	Refer to Operation Manual

◎ FUEL SYSTEM

Bosch type in-line pump with integrated, electromagnetic actuator.

○ Injection pump	Bosch in-line "P" type
○ Governor	Electric type
○ Speed drop	G3 Class (ISO 8528)
○ Feed pump	Mechanical type in injpump.
○ Injection nozzle	Multi hole type
○ Opening pressure	28 MPa
○ Fuel filter	Full flow, cartridge type with water drain valve.
○ Maximum fuel inlet restriction	30 kPa
○ Maximum fuel return restriction	60 kPa
○ Fuel feed pump Capacity	315 liters / hr
○ Used fuel	Diesel fuel oil

◎ ELECTRICAL SYSTEM

○ Battery Charging Alternator	27.5V x 45A alternator
○ Voltage regulator	Built-in type IC regulator
○ Starting motor	24V x 7.0 kW
○ Battery Voltage	24V
○ Battery Capacity	2 x 200 Ah (recommended)
○ Starting aid (Option)	Block heater

◎ VALVE SYSTEM

○ Type	Overhead valve type	
○ Number of valve	Intake 1, exhaust 1 per cylinder	
○ Valve lashes at cold	Intake 0.25 mm , Exhaust 0.35 mm	
○ Valve timing		
	Opening	Close
- Intake valve	24 deg. BTDC	36 deg. ABDC
- Exhaust valve	63 deg. BBDC	27 deg. ATDC

◎ PERFORMANCE DATA

		Prime Power		Standby Power	
○ Governed Engine speed	rpm	1500	1800	1500	1800
○ Engine Idle Speed	rpm	800	800	800	800
○ Over speed limit	rpm	1650	1980	1650	1980
○ Gross Engine Power Output	kW	464	505	510	556
	PS	630	687	693	756
○ Break Mean effective pressure	MPa	2.53	2.30	2.78	2.53
○ Mean Piston Speed	m/s	7.1	8.5	7.1	8.5
○ Friction Power	kW	32	44	32	44
	PS	43.5	59.8	43.5	59.8
○ Specific fuel consumption					
25% load	liters/hr	30.3	35.2	32.3	37.4
50% load	liters/hr	55.1	62.3	60.9	68.1
75% load	liters/hr	83.4	92.9	91.1	101.0
100% load	liters/hr	115.1	127.1	127.8	139.6
○ Maximum Lube oil consumption	g/h	441	481	485	529
○ Fan Power	kW	16	24	16	24
○ Sound Pressure at 1m from the each side of Cylinder Block					
(without Fan)	dB(A)	97.65	100.33	97.65	100.33

The all data and the specific fuel consumption are based on ISO 3046/1, Standard reference conditions are in accordance with 298 K(25° Celsius) air temperature, 100kPa(1000mbar) air pressure, 60% relative humidity, 110m(361ft) altitude.

◎ Engine Data with Dry Type Exhaust Manifold

○ Intake Air Flow	m ³ /min	30.8	34.2	33.1	36.6
○ Exhaust gas temp. after turbo.	°C	536	539	561	567
○ Exhaust Gas Flow	m ³ /min	90	100	98	108
○ Heat Rejection to Exhaust	kW	426	470	473	517
○ Heat Rejection to Coolant	kW	204	225	226	247
○ Heat Rejection to Intercooler	kW	104	115	115	126
○ Radiated Heat to Ambient	kW	43	48	48	52
○ Cooling water circulation	liters/min	590	660	590	660
○ Cooling fan air flow	m ³ /min	700	850	700	850

© DERATING FROM ISO 3046 STANDARD CONDITIONS

The maximum power is the STANDBY rating when assessing derate parameters.

Ambient temperature is air inlet temperature.

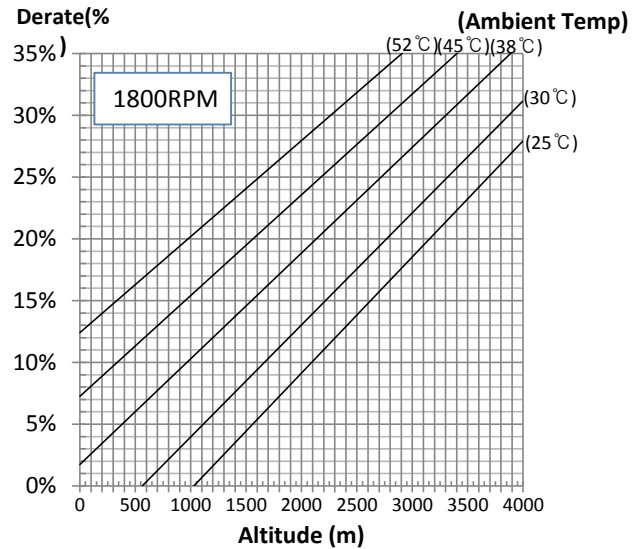
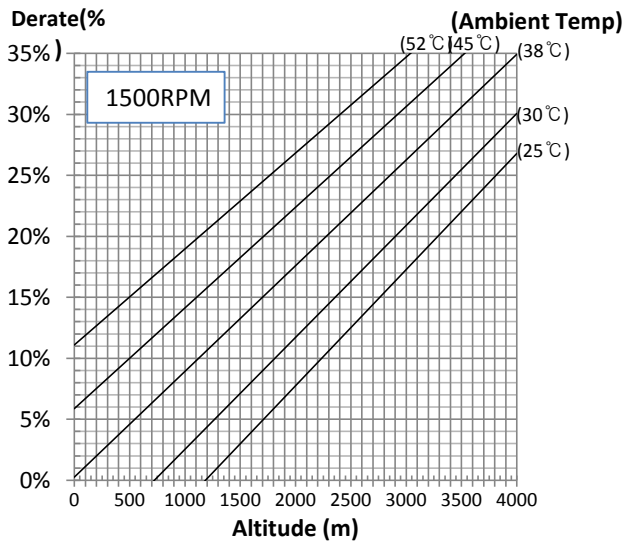

© ENGINE DIMENSION

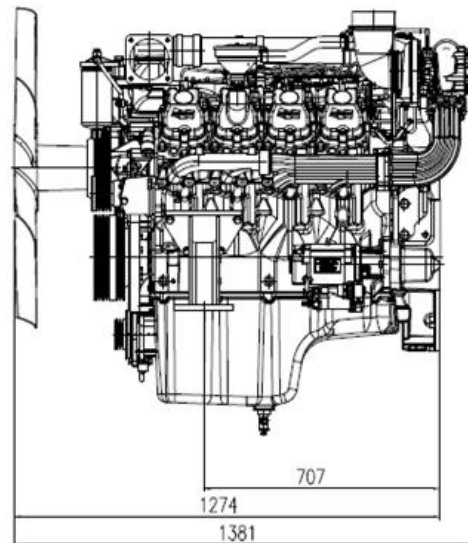
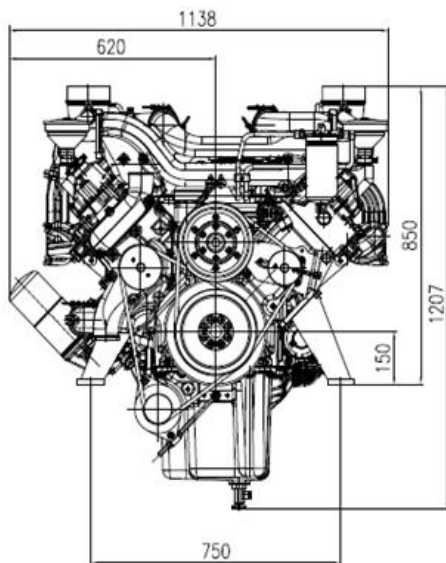

◆ CONVERSION TABLE

in. = mm x 0.0394
 PS = kW x 1.3596
 psi = kg/cm² x 14.2233
 in³ = lit. x 61.02
 hp = PS x 0.98635
 lb = kg x 2.20462
 kW = kcal/sec x 0.239

lb/ft = N.m x 0.737
 U.S. gal = lit. x 0.264
 kW = 0.2388 kcal/s
 lb/PS.h = g/kW.h x 0.00162
 cfm = m³/min x 35.336
 MPa = kPa x 1000 = bar x 10

Doosan Infracore Co., Ltd.
 21st Floor, Doosan Tower, 18-12, Euljiro 6-ga,
 Jung-gu, Seoul, Korea.

TEL : +82-2-3398-8578 / FAX : +82-2-3398-8509
E-mail : enginesales@doosan.com
Web site : www.doosaninfracore.com

※ Specifications are subject to change without prior notice.