

DATA SHEET

DIESEL GENERATOR 400KW

MODEL#FDK-CD400/H1

50HZ/1500RPM

CUMMINS MODEL: QSZ13-G2



General Features:

- ♦ All qualified generator sets are subjected to a comprehensive performance test which includes 50% load, 70% load, 100% load, 110% load and to check, verify that all control systems, alarm and shut-down protection.
- ♦ Equipped with battery charger and 24V high performance maintenance-free lead-acid starting batteries and connecting cables.
- ♦ Stainless galvanized zinc plates with strong corrosion-proof.
- ♦ Vibration isolators between the engine/alternator and base frame.
- ♦ Equipped with industrial silencer and flexible exhaust hose.
- ♦ Designed to comply with ISO8528/GB2820.
- ♦ Powered by Cummins engine and coupled with Stamford alternator.
- ♦ Water jacket preheater, oil heater and double air cleaner, etc. are available.

FDK Diesel Generator Set Data

Genset Model	FDK-CD400/H1
Prime Power	360KW/454KVA
Standby Power	400KW/500KVA
Output Frequency / Rated speed	50Hz/1500rpm
Rated Voltage	230V/400V

Engine Make	Cummins
Engine Model	QSZ13-G2
Alternator model	Stamford HCI544C
Control System	DSE7320
Phase	Three

(1) **Prime power:** The rating is available for an unlimited of annual operating hours in variable load applications, in accordance with ISO8528-1.A 10% overload is available for a period of 1 hour within 12-hour period of operation, in accordance with ISO 3046-1.

(2) **Standby power:** The rating is applicable for supplying emergency power in variable load applications for up to 200 hours per year in accordance with ISO8528-1. Overload is not allowed.

(3) **Rated voltage:** available with customer requirement.

Engine Specifications (DETAILED in APPENDIX)

Engine Model	QSZ13-G2
Engine Manufacturer	Cummins (China Dongfeng)
Cylinder quantity	6
Cylinder Arrangement	Not available
Cycle	Not available

Aspiration	Turbo-charged
Bore x Stroke (mm x mm)	130x163
Displacement	13L
Compression Ratio	17:1
Prime power / Speed (KW/RPM)	400/1500
Standby power/ Speed (KW/RPM)	440/1500



Speed governor	MCRS	Fuel Consumption at 100% load (g/KWh)	194 at 1500rpm
Piston Speed	8.15m/s	Starter motor	DC24V
Friction Energy Output	31kw	Alternator	DC24V
Total Lubrication System Capacity (L)	45.42	Low idle	700rpm
Coolant Capacity (L)	23.1		

Alternator Specifications

Alternator model	HCI544C	Number of phase	3
Alternator manufacturer	STAMFORD	Rated voltage	400V (Available with custom requirements)
Exciter type	Single bearing, Brushless, Self-excited	Power factor	0.8
Rated output prime power	500KVA	Voltage regulation NL-FL	≤±1%
Rated speed	1500 rpm	Insulation grade	H
Rated frequency	50Hz	Protection grade	IP23

Alternator option: Leroy Somer, MECC, Marathon, Engga, Faraday

Control System DSE7320 (DETAILED in INSTRUCTION)

DSE7320 is an advanced control module based on micro-processor, containing all necessary functions for protection of the genset and the breaker control. It can monitor the mains supply, breaker control and automatically start the engine when the mains are abnormal. Accurately measure various operational parameters and display all values and alarms information on the LCD. In addition, the control module can automatically shut down the engine and indicate the engine failure.

FEATURES

- Microprocessor control, with high stability and credibility.
- Monitoring and measuring operational parameters of the mains supply and genset.
- Indicating operation status, fault conditions, all parameters and alarms.
- Multiple protections; multiple parameters display, like pressure, temp. etc.
- Manual, automatic and remote work mode selectable.
- Real time clock for time and date display, overall runtime display, 250 log entries.
- Overall power output display.
- Integral speed/frequency detecting, telling status of start, rated operation, overspeed etc.
- Communication with PC via RS485 OR RS232 interface, using MODBUS protocol.

Soundproof Enclosure Specification

FDK silent generator is designed by professional acoustic engineers based on years of experience. Now we can make the noise of the generator less than 80-85dB(A) at 1m, or 70-75dB(A) at 7m, 60-65dB(A) at 15m.

FEATURES

- Multi-way air intake and exhaust guarantee the power performance of the generator.
- Large-scale impedance combined type silencer effectively reduce noise of the generator.
- Internal high performance rubber damper and flexible materials reduce vibration.
- Base mounted fuel tank supports the generator running for 8 hours.



ISO9001:2008

FDK reserves the right to change the specifications and designs without notice.

Optional

Generator set	Alternator	Low environment Temp	ATS
<input type="checkbox"/> Open generator set <input type="checkbox"/> Silent generator set <input type="checkbox"/> Trailer generator set <input type="checkbox"/> ABB MCCB circuit breaker	<input type="checkbox"/> Stamford <input type="checkbox"/> Marathon <input type="checkbox"/> Mecc Alte <input type="checkbox"/> Leroy Somer <input type="checkbox"/> Farady <input type="checkbox"/> Engga	<input type="checkbox"/> Water heater <input type="checkbox"/> Oil heater <input type="checkbox"/> Battery heater	<input type="checkbox"/> CHINT <input type="checkbox"/> SCHNEIDER <input type="checkbox"/> ABB
Fuel system	Control system	Voltage	Synchronized system
<input type="checkbox"/> 12hrs base tank <input type="checkbox"/> 24hrs base tank <input type="checkbox"/> Dual wall base fuel tank <input type="checkbox"/> Outside fuel tank	<input type="checkbox"/> AMF function <input type="checkbox"/> ATS control cabinet <input type="checkbox"/> DSE7320 <input type="checkbox"/> DSE7510 <input type="checkbox"/> GU620A	<input type="checkbox"/> 415/240V <input type="checkbox"/> 400/230V <input type="checkbox"/> 380/220V <input type="checkbox"/> 220/127V <input type="checkbox"/> 200/115V	<input type="checkbox"/> CHINT Cabinet <input type="checkbox"/> SCHNEIDER Cabinet <input type="checkbox"/> DSE8610 Module <input type="checkbox"/> COMAQ Module <input type="checkbox"/> DEIF Module

Dimension & Weight

Open

Overall Size: LxWxH (mm)	3400x1400x1800
Weight (kg)	3050

Soundproof Version

Overall Size: LxWxH (mm)	5000x1900x2250
Weight (kg)	5400

Sales Promises

- ◆ FDK provides a full line of brand new and high quality products. Each and every unit is strictly factory tested before shipment.
- ◆ Quality warranty is according to our standard conditions: 12 months from BL date or 1000 running hours, whichever comes first.
- ◆ Service and parts are available from FDK or distributors in your location.
- ◆ FDK guarantee use **BRAND NEW & GENUINE MACHINE.**



东风康明斯发动机 性能参数表

发动机型号：QSZ13-G2

性能曲线号：FR20287

版本03 2012年6月发布



发电机组用发动机性能参数表

东风康明斯发动机有限公司
中国 湖北 襄樊

发动机型号

QSZ13-G2

性能曲线号

FR20287

性能控制部件号

3718

压缩比: 17:1

缸数: 6

缸径: 130 mm

冲程: 163 mm

排量: 13.0 L

发动机配置号: D0C3004GX03

燃油系统: 电控高压共轨喷射系统

进气形式: 涡轮增压 & 进气空空中冷

调速率: ≤1%

排放认证: 中国 II 阶段

发动机功率*:

发动机转速 r/min	备用功率		额定功率		持续功率	
	bhp	kWm	bhp	kWm	bhp	kWm
1500	589	440	536	400	455	340
1800	589	440	536	400	455	340

*各功率定义依照AEB26.02。

1500转发动机性能参数

输出功率			燃油消耗			
%	bhp	kWm	lb/bhp.h	g/kWm.h	gal/h	l/h
备用功率						
100	589	440	0.317	193	374	98.7
额定功率						
100	536	400	0.314	191	337	88.8
75	402	300	0.309	188	249	65.6
50	268	200	0.313	190	167	44.2
25	134	100	0.334	203	89	23.6
持续功率						
100	455	340	0.311	189	283	74.7

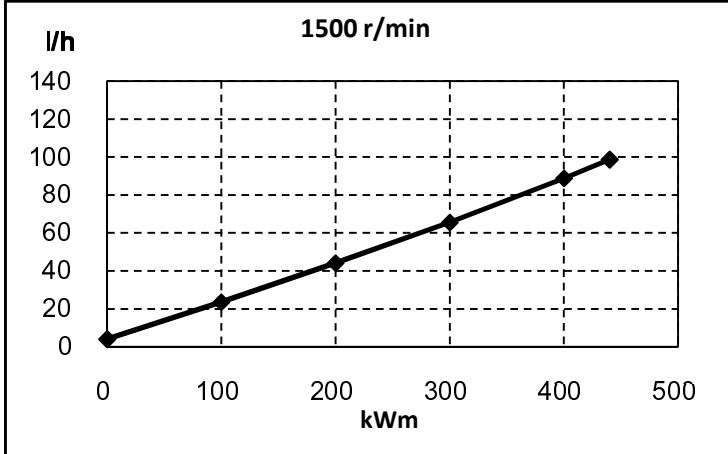

1800转发动机性能参数

输出功率			燃油消耗			
%	bhp	kWm	lb/bhp.h	g/kWm.h	gal/h	l/h
备用功率						
100	589	440	0.327	199	386	101.8
额定功率						
100	536	400	0.319	194	342	90.2
75	402	300	0.317	193	255	67.3
50	268	200	0.321	195	172	45.3
25	134	100	0.357	217	96	25.2
持续功率						
100	455	340	0.317	193	289	76.3

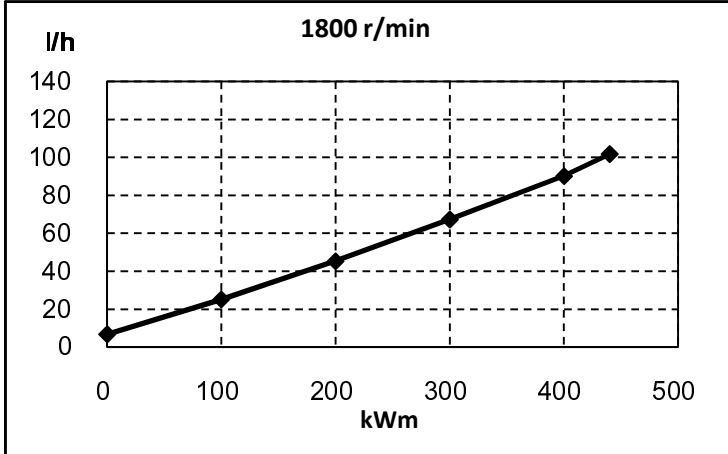

以上性能数据在大气压力100kPa, 进气温度25℃, 海拔高度80m, 使用标准0#柴油下, 按照GB/T18297试验条件获得。

试验时, 发动机不带空气压缩机、发电机、风扇、选装件及驱动件;

试验条件为进气阻力3.7kPa, 排气阻力10kPa。

发动机允许持续运转最高海拔高度为5200m。



发电机组用发动机性能参数表

东风康明斯发动机有限公司
中国 湖北 襄樊

发动机型号

QSZ13-G2

性能曲线号

FR20287

性能控制部件号

3718

1500转时，发动机随海拔升高功率下降曲线
备用功率

1800转时，发动机随海拔升高功率下降曲线
备用功率

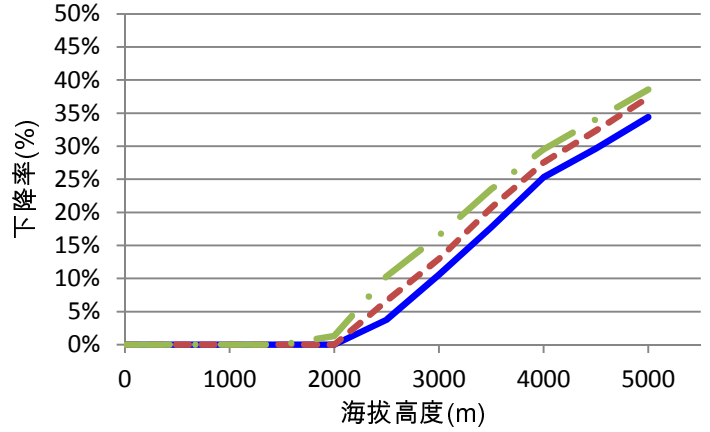
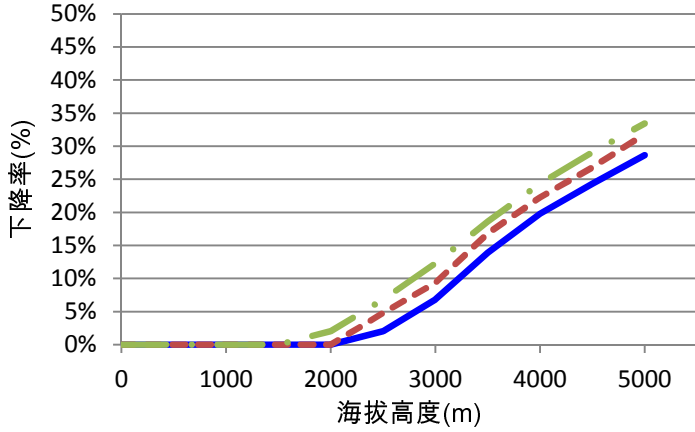

额定功率

额定功率

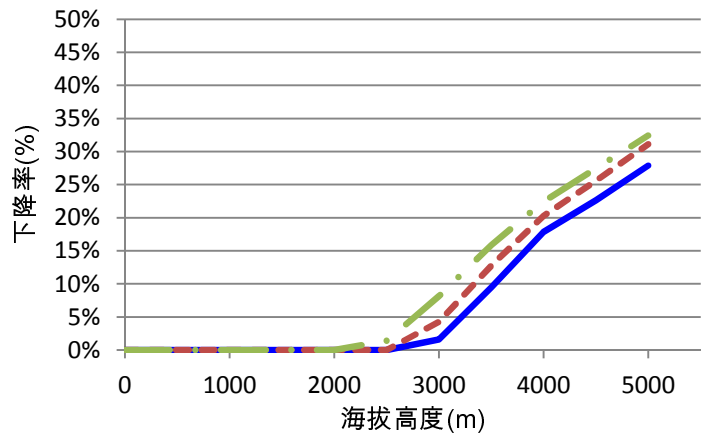
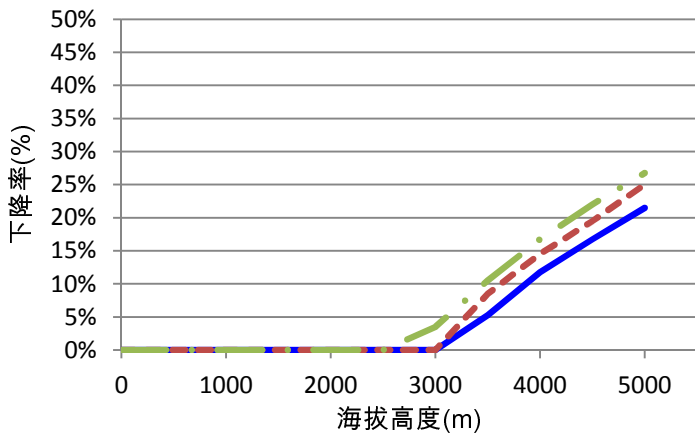

持续功率

持续功率

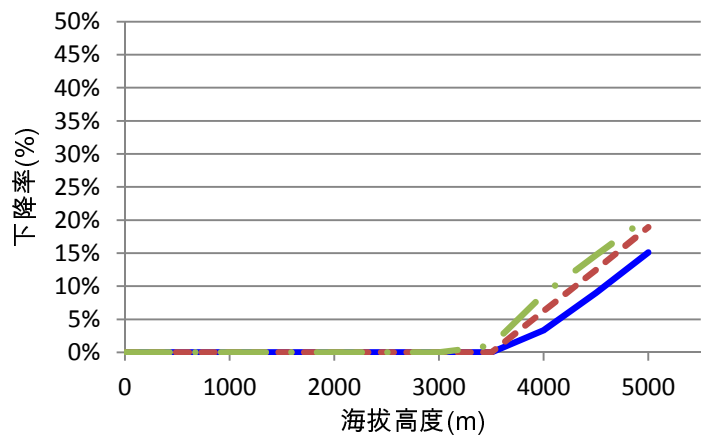
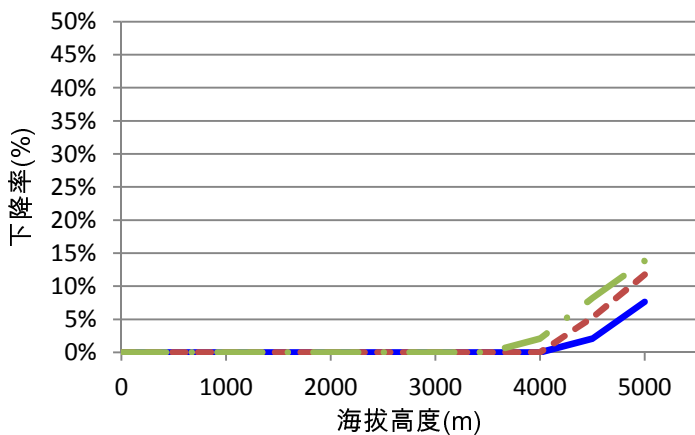

进气温度 ——— 25 °C (77°F) - - - - 40 °C (104°F) ····· 50 °C (122°F)

以上数据在ISA (国际标准大气) 规定的压力条件下测量，中冷后温50度，进气阻力3.7kPa，排气阻力10kPa。



发电机组用发动机性能参数表

东风康明斯发动机有限公司
中国 湖北 襄樊

发动机型号

QSZ13-G2

性能曲线号

FR20287

性能控制部件号

3718

概要

发动机形式:	直列6缸、四冲程
进气形式:	涡轮增压、进气空空中冷
压缩比:	17:1
点火顺序:	1-5-3-6-2-4
缸径 x 冲程:	- mm 130 x 163
排量:	- L 13.0
低怠速:	- r/min 700
最大许用海拔高度:	- m 5200
干重:	- kg 1245
湿重:	- kg 1310
重心距缸体前端面距离:	- mm 519
重心距曲轴中心线距离 (曲轴之上):	- mm 201
发动机旋转惯量 (不带飞轮):	- kg.m ² 1.48

发动机安装

缸体后端面允许最大弯矩:	- N.m 1356
风扇最大静止安装弯矩:	- N.m 21
发动机支撑能承受的最大质量:	- kg 1500

进气系统

推荐的发动机进气总管内径:	- mm 200
推荐的中冷系统最小等效内径:	- mm 115
环境与增压器进气口之间的最大进气温升:	- °C 11.1
环境和进气歧管之间的最大进气温升:	- °C 30
不会导致发动机性能下降的最大中冷后温 (海平面时):	- °C 60*
中冷后温报警温度 (发动机保护):	- °C 85
最大进气阻力:	
净滤芯:	- kPa 3.2
脏滤芯:	- kPa 6.2
最大中冷系统阻力:	- kPa 13

排气系统

系统允许的最大排气阻力:	- kPa 13
排气口法兰面所能承受的最大静止弯矩:	- N.m 27
推荐的排气管最小内径:	- mm 130

*指发动机的耐久性、可靠性及动力性能在超过此温度后可能会受到损失。



发电机组用发动机性能参数表

东风康明斯发动机有限公司
中国 湖北 襄樊

发动机型号

QSZ13-G2

性能曲线号

FR20287

性能控制部件号

3718

润滑系统

怠速最低油压:	- kPa	82.7
热机时通常油压范围:	- kPa	207 - 276
全润滑系统容积:	- L	45.42
润滑系最大流速:	- L/min	7.57

冷却系统

发动机冷却液容积 (仅发动机):	- L	23.1
节温器标准调节温度:	- °C	82
节温器全开温度:	- °C	94
最高冷却液温度 (发动机出口):	- °C	102
最低冷却液温度:	- °C	71
冷却液报警温度:	- °C	107
最大冷却液压力 (不带压力盖, 节温器关闭):	- kPa	407
允许的最小压力盖压力:	- kPa	103
外部冷却系统最大阻力:	- kPa	75
最大除气时间:	- min	25
最低加水速率:	- L/min	19
最大冷却液膨胀容积 (占冷却系统容量的百分比):	- %	10
最小冷却液膨胀容积 (占冷却系统容量的百分比):	- %	6

燃油系统

最大燃油供油阻力 (OEM端):	- kPa	13.5
最大燃油回油阻力:	- kPa	27
油箱最小放油能力:	- L/s	0.2
最高燃油温度 (在输油泵进口处):	- °C	71
最大燃油散热损耗:	- kW	5.36
最大燃油设计流量:	- kg/h	204

电气系统

系统电压:	- V	24
最小被推荐的电瓶容量, 不低于-18°C的温度		
冷启动电流:	- CCA	900
电瓶容量:	- min	270

冷起动系统

无辅助起动装置时的最低冷起动温度:	- °C	-15
带辅助起动装置 (进气预热) 时的最低冷起动温度:	- °C	-30

排放

按照GB 20891-2007 进行排放检测:	1500 r/min	1800 r/min
-NO _x :	- g/kW.h	5.023 4.978
-HC:	- g/kW.h	0.112 0.103
-CO:	- g/kW.h	0.379 0.451
-微粒:	- g/kW.h	0.020 0.034



发电机组用发动机性能参数表

东风康明斯发动机有限公司
中国 湖北 襄樊

发动机型号

QSZ13-G2

性能曲线号

FR20287

性能控制部件号

3718

性能数据

所有数据根据GB18297 发动机性能试验方法获得

试验条件:

- 大气压力为100kpa
- 进气温度为25摄氏度
- 海拔高度为80m
- 空气湿度为50%

试验时, 发动机不带空气压缩机、发电机、风扇、选装件及驱动件;

稳态时, 所有数据允差范围为±5%;

		备用功率		额定功率	
		1500	1800	1500	1800
发动机转速	r/min	1500	1800	1500	1800
输出功率:	kWm	440	440	400	400
扭矩:	N.m	2801	2334	2547	2122
平均有效压力	kPa	2708	2256	2462	2051
活塞速度	m/s	8.15	9.78	8.15	9.78
摩擦损失功率	kW	31	45	31	45
冷却液流量	L/min	366	438	366	438
燃油消耗量	kg/h	84.9	87.6	76.4	77.6
发动机数据					
进气流量	m ³ /min	29.7	35.8	28.3	33.3
排气温度	°C	530	473	509	449
排气流量	kg/min.	36.4	43.8	34.7	40.6
空燃比		24.7	29.0	26.2	30.4
热损失功-环境	kW	71	71	65	65
热损失功-冷却液	kW	152	162	123	141
热损失功-排气	kW	381	381	346	346
热损失功-燃油*	kW	5	5	5	5
进气中冷					
热损失功-中冷器	kW	93	106	85	100
增压器压后压力	kPa	250	245	226	225
增压空气流量	kg/min	35.0	42.3	33.4	39.3
增压器压后温度	°C	198	198	189	183

*表中所列为最大热损失功

TBD: 待定

N/A: 不适用

数据如有更改, 恕不另行通知

东风康明斯发动机有限公司



发电机组用发动机性能参数表

东风康明斯发动机有限公司
中国 湖北 襄樊

发动机型号

QSZ13-G2

性能曲线号

FR20287

性能控制部件号

3718

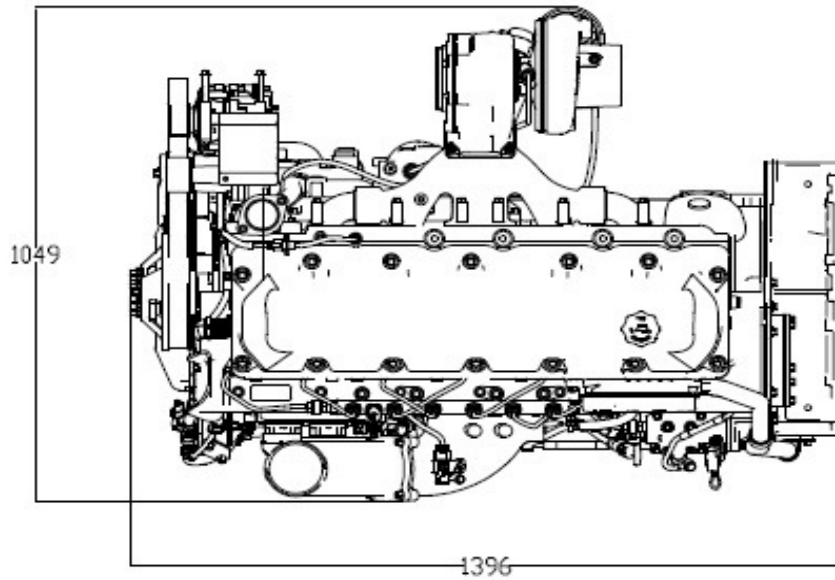
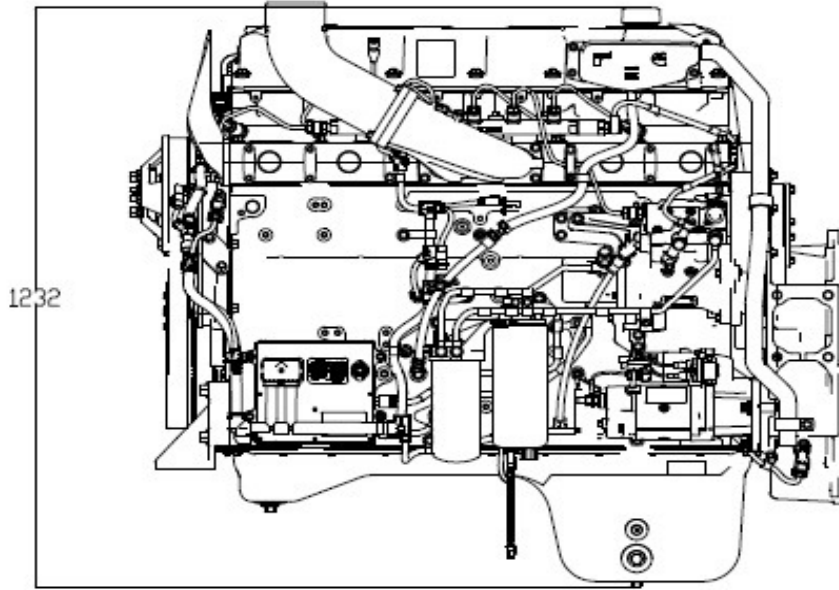



发电机组用发动机性能参数表

东风康明斯发动机有限公司
中国 湖北 襄樊

发动机型号

QSZ13-G2

性能曲线号

FR20287

性能控制部件号

3718

备用功率机型：仅用于应急电站，没有超载能力，每年累计运行时间小于200小时、平均负荷率低于80%，其中在备用功率点的运行时间每年不超过25小时。

常用功率机型：不限时使用，有超载能力，但任意250小时的负荷率不应超过常用功率的70%；在常用功率上的运行时间每年不能超过500小时。每12小时内最多只能超载运行1小时，每年的累积超载时间不超过25小时。

持续功率机型：保持在100%负荷连续运行，不提供超载能力

东风康明斯发动机有限公司
湖北省襄樊市汽车产业开发区
邮编：441004
公司总机：86-710-3399100
公司传真：86-710-3392893

结束

7